



Floral Display Merchandisers



M P s e r i e s

Natural environment floral refrigeration units



W H E N O N L Y T H E B E S T W I L L D O

MP SERIES

FLORALWALL™ refrigerated displays offer advanced design features that provide unmatched superiority in styling, performance and durability. Exclusive features include Floraline's patented self-watering/self-cleaning system that extends product shelf life and reduces shrink of floral bouquets and cut flowers. This industry-first feature minimizes maintenance and frees your personnel for more important tasks.

The MP series is a low-profile display that allows you to create unique configurations. This modular, open-front floral merchandiser is elegantly designed for maximum product visibility and impulse buying.

STANDARD FEATURES

- Patented self-watering/self-cleaning system replenishes water automatically; keeping it fresh for floral bouquets.
- Long-lasting, high-output SPX35 lamps for truer, more natural floral presentation.
- Soft Air Flow Environment. A refrigeration envelope is created by directional air flow simulating a closed-door environment. Protects even the most delicate flowers.
- Polyurethane foamed in place insulation.
- Under case air return.
- Charcoal-impregnated water filter system removes harmful chemicals.
- Dual air pattern for environmental control.
- Vases sit at 15° to enhance visibility.
- Mirrored backwall and mirrored ends for brighter, more bountiful appearance.
- Full selection of exterior laminate colors to complement your store decor.

Contact your Floraline representative for more details.



MP SERIES & MORE

Floraline manufactures a complete selection of open-air and closed-door floral merchandisers that complement the MP series. Our custom-design services and cabinet department can tailor these displays for your specific requirements.

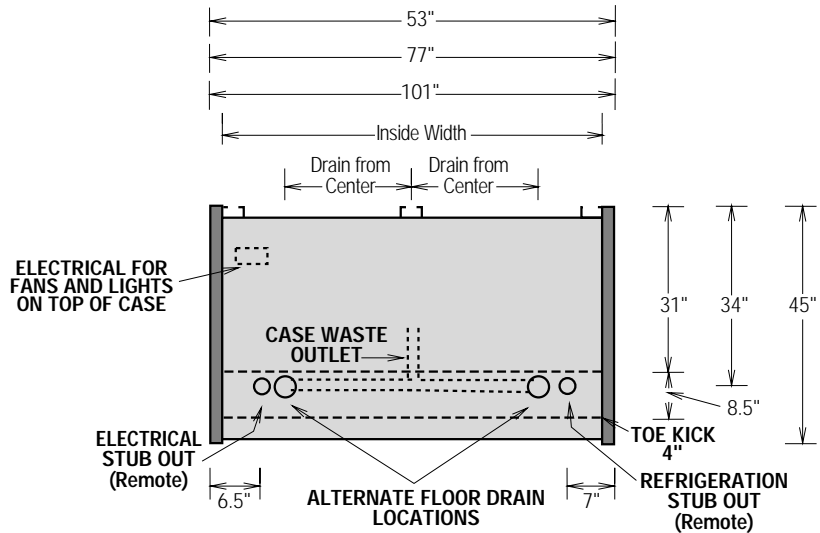
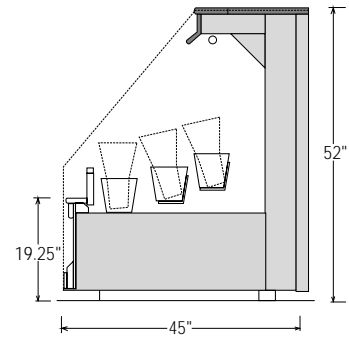

(also available in 10' and 12' models)

MODEL	MP4	MP6	MP8
Overall width	53"	77"	101"
Inside width	48.5"	72.5"	96.5"
Overall depth	45"	45"	45"
Overall height	52"	52"	52"
Drain from center	16"	24"	24"
Utilities from wall	34"	34"	34"
Lights Amp	0.7	0.8	1.1
Fans Amp (115V 1PH 60HZ)	0.5	0.5	1.1
Vases (8" center to center)	16	25	34
Capacity (3 bouquets/vase)	48	75	102
H2O Transformer AMP (Max.)	1.5	1.5	1.5
BTU's@25° (R22 Standard)	2,640	3,960	5,280
Anti-Sweat AMP	N/A	N/A	N/A
Compressor	N/A	N/A	N/A
Maximum Fuse Size	N/A	N/A	N/A
Defrost - two 30 minutes	yes	yes	yes



Floriline Display Products

38160 Western Parkway • Willoughby, OH 44094
 Phone: 800.239.3722 • 440.975.9449 • Fax: 440.918.9043
 e-mail: info@floralinedisplay.com • web: www.floralinedisplay.com